

Licensing Sub-Committee Report

Item No:	
Date:	3 March 2016
Licensing Ref No:	15/07477/LIPN - New Premises Licence
Title of Report:	Restaurant 1 Grosvenor Gardens London SW1W 0BG
Report of:	Director of Public Protection and Licensing
Wards involved:	St James's
Policy context:	City of Westminster Statement of Licensing Policy
Financial summary:	None
Report Author:	Mr Ola Owojori Senior Licensing Officer
Contact details	Telephone: 020 7641 7830 Email: owojori@westminster.gov.uk

1. Application

1-A Applicant and premises			
Application Type:	New Premises Licence, Licensing Act 2003		
Application received date:	4 September 2015		
Applicant:	Grosvenor Gardens Leisure Ltd		
Premises:	Restaurant		
Premises address:	1 Grosvenor Gardens London SW1W 0BG	Ward:	St James's
		Cumulative Impact Area:	No
Premises description:	The premises are to be operated as a restaurant/bar on the ground and basement floors		
Premises licence history:	The premises have not been previously licensed.		
Applicant submissions:	The applicant has submitted the City Council's permission discharging the servicing conditions on the planning permission. See Appendix 2		

1-B Proposed licensable activities and hours							
Late Night Refreshment:				Indoors			
Day:	Mon	Tues	Wed	Thur	Fri	Sat	Sun
Start:	23:00	23:00	23:00	23:00	23:00	23:00	N/A
End:	23:30	23:30	23:30	23:30	00:00	00:00	N/A
Seasonal variations:	From the end of permitted hours on New Year's Eve to 05:00 on New Year's Day						
Non-standard timings:	Sunday before Bank Holiday 23:00 – 00:00						

Sale by retail of alcohol				On or off sales or both:			
Day:	Mon	Tues	Wed	Thur	Fri	Sat	Sun
Start:	10:00	10:00	10:00	10:00	10:00	10:00	12:00
End:	23:30	23:30	23:30	23:30	00:00	00:00	22:30
Seasonal variations:	From the end of permitted hours on New Year's Eve to the start of permitted hours on New Year's Day						
Non-standard timings:	Sunday before Bank Holiday 10:00 – 00:00						

Hours premises are open to the public							
Day:	Mon	Tues	Wed	Thur	Fri	Sat	Sun
Start:	07:00	07:00	07:00	07:00	07:00	07:00	07:00
End:	23:30	23:30	23:30	23:30	00:00	00:00	22:30

Seasonal variations:	From the end of permitted hours on New Year's Eve to the start of permitted hours on New Year's Day
Non-standard timings:	Sunday before Bank Holiday 07:00 – 00:00
Adult Entertainment:	N/A

2. Representations

2-A Responsible Authorities	
Responsible Authority:	Environmental Health
Representative:	Ian Watson
Received:	2 October 2015
<p>This representation is based on the plans and operating schedule submitted.</p> <p>The applicant is seeking the following</p> <ol style="list-style-type: none"> 1. To provide for the Supply of Alcohol 'On' and 'Off' the premises Monday to Thursday between 10.00 and 23.30 hours, Friday and Saturday 10.00 and 00.00 hours and Sunday between 12.00 to 22.30 hours. Sunday prior to Bank Holiday 10.00 to 00.00 hours. 2. To provide Late Night Refreshment 'Indoors' Monday to Thursday 23.00 to 23.30 hours, Friday and Saturday 23.00 to 00.00 hours. Sunday prior to Bank Holiday 23.00 to 00.00 hours. 3. On New Year's Eve to provide Supply of Alcohol and Late Night Refreshment from the end of authorised hours to commencement of authorised hours on New Year's Day. <p>I wish to make the following representation</p> <ol style="list-style-type: none"> 1. The provision and hours requested for the Supply of Alcohol will have the likely effect of causing an increase in Public Nuisance within the area. 2. The provision and hours requested to permit the provision of Late Night Refreshment will have the likely effect of causing an increase in Public Nuisance and impact on Public Safety within the area. 3. The hours requested to permit the provision of Supply of Alcohol and Late Night Refreshment from the end of authorised hours on New Year's Eve to commencement of authorised hours on New Years Day will have the likely effect of causing an increase in Public Nuisance within the area. <p>The granting of the application as presented would have the likely effect of causing an increase in Public Nuisance and impact on Public Safety within the area.</p> <p>The applicant has provided conditions in support of the application but these do not fully address the concerns of Environmental Health.</p> <p>The following conditions are proposed by Environmental Health.</p> <ul style="list-style-type: none"> • The number of persons permitted in the premises at any one time (excluding staff) shall not exceed 	

Ground Floor xxx persons.
Basement xxx persons.

- No noise generated on the premises, or by its associated plant or equipment, shall emanate from the premises nor vibration be transmitted through the structure of the premises which gives rise to a nuisance.
- All sales of alcohol for consumption off the premises shall be in sealed containers only, and shall not be consumed on the premises.
- No collections of waste or recycling materials (including bottles) from the premises shall take place between 23.00 and 08.00 hours on the following day.
- No deliveries to the premises shall take place between 21.00 and 08.00 hours on the following day.
- The emergency exit door leading onto Grosvenor Gardens Mews East shall be self-closing and remain closed when the premises are operating under the authority of the licence.
- The approved arrangements at the premises, including means of escape provisions, emergency warning equipment, the electrical installation and mechanical equipment, shall at all material times be maintained in good condition and full working order.
- The means of escape provided for the premises shall be maintained unobstructed, free of trip hazards, be immediately available and clearly identified in accordance with the plans provided.
- All emergency exit doors shall be available at all material times without the use of a key, code, card or similar means.
- All emergency doors shall be maintained effectively self-closing and not held open other than by an approved device.
- The edges of the treads of steps and stairways shall be maintained so as to be conspicuous.
- Curtains and hangings shall be arranged so as not to obstruct emergency safety signs or emergency equipment.

Responsible Authority:	Metropolitan Police
Representative:	Toby Janes
Received:	1 October 2015

With reference to the above application, I am writing to inform you that the Metropolitan Police, as a Responsible Authority, make a representation against the above application.

It is our belief that if granted the application would undermine the Licensing objectives in relation to the prevention of crime and disorder as there are insufficient conditions

within the operating schedule.

The following conditions listed below are those that police would like you to attach to your operating schedule as I believe they will address police concerns in relation to crime and disorder.

1. All sales of alcohol for consumption off the premises shall be in sealed containers only and shall not be consumed on the premises.
2. The supply of alcohol for consumption 'On' the premises shall be by waiter/waitress or bar service only.
3. There shall be no supply of alcohol for consumption 'Off' the premises after 22.00 hours.

Based on your agreement to police conditions, I can confirm police now withdraw our representation.

2-B Other Persons			
Name:		Miss Imogen Badley	
Address and/or Residents Association:		Grosvenor Gardens Mews East Beeston Place London SW1W 0JW	
Received:	1 October 2015		
Status:	Resident	In support or opposed:	Opposed
I am writing to object to this application on the grounds of 'prevention of public nuisance'.			
I live in Grosvenor Mews East which is at the back of the proposed restaurant site. I believe that the proposal is for all deliveries and waste collection will take place at the rear of the property via the mews. The mews is very small and any noise from these activities will cause a serious nuisance to all of the residents especially if they take place after the premises close at midnight or very early in the morning.			
Name:		Mr Sean Stowell	
Address and/or Residents Association:		Grosvenor Gardens Mews Beeston Place London SW1W 0JN	
Received:	1 October 2015		
Status:	Resident	In support or opposed:	Opposed
I am writing to object to this application on the grounds of 'prevention of public nuisance'.			
I live in Grosvenor Mews East which is at the back of the proposed restaurant site. I believe that the proposal is for all deliveries and waste collection will take place at the			

rear of the property via the mews. The mews is very small and any noise from these activities will cause a serious nuisance to all of the residents especially if they take place after the premises close at midnight or very early in the morning.

In addition, it looks like this will be the staff entrance to the property which will again cause a disturbance as they leave in the early hours of the morning when their shifts end.

Name:	Goring Hotel		
Address and/or Residents Association:	Beeston Place London SW1W 0JW		
Received:	29 September 2015		
Status:	Business	In support or opposed:	Opposed

We have grave concerns regarding the impact of the new proposed restaurant at 1 Grosvenor Gardens. For this reason we feel we have no alternative but to lodge an objection to the application for a liquor license.

May I start by saying that we are very excited that the whole Victoria area is being developed at the moment. There is no doubt this will be one of the great areas within Westminster. As a board member of VBID I am particularly excited by all the recent improvements being made to Victoria.

My concern with this particular application is the impact that it will have on those people living in Grosvenor Gardens Mews East. We have a number of our staff living in the mews accommodation above the garages which we lease from The Grosvenor Estate. We also own flat number 11, which we rent out to a very nice young lady. It is our belief that these people are going to be adversely affected, when the restaurant starts to trade, by the access door to the mews.

It would appear that all the rubbish will come out of here, all the goods will go into here and it will be the staff entrance / exit.

It is my belief that when the restaurant closes at night there will be all sorts of activity within in the confines of the mews such as throwing away empty bottles, disposing of food waste and also general waste. Added to this the staff when leaving early in the morning are bound to cause noise and disruption to those people living in the mews.

The confined nature of the mews which is surrounded on all sides by house and walls leads to an increase in perceived noise levels. All of the above I believe will appear even noisier than they already are and will therefore appear event more disruptive. I am very concerned that our staff and tenants will be unable to open their windows during the summer nights because of the increased late night noise.

We are also deeply concerned about damage to cars in our car park. Whilst most of the delivery vans will no doubt park in Beeston Place, some of them will drive into the mews in order to shorten the distance they need to travel on foot with their goods. We have a number of exceedingly high end cars belonging to guests which are parked in the mews. We fear that these are much more likely to be damaged with such an enormous possible increase in deliveries. At present very few vans and no small lorries go into the mews.

It is on all of the grounds outlined above that I would like to place on record an object to the application.

Finally, Beeston Place is a fairly small yet reasonably busy street. Over the past few years, two new licenses have been granted on the corners of Beeston Place and Grosvenor Gardens. The impact of these new licensed restaurants has been considerable on the area. One of them has tables and chairs all along the pavements. These encroach far beyond the boundaries of the property. During the summer months and any warm spring and autumn days there are so many people sitting and standing drinking on the pavement that you have to walk into the road to go around them.

There has also been an enormous increase in the number of delivery lorries parking on Beeston Place. Some of these are delivering good to businesses in Grosvenor Gardens (a red route), however, delivery to restaurants are much more intrusive. By their very nature, restaurants require a number of deliveries from many different suppliers. There is no doubt that the deliveries to this new restaurant will be made via an already unbelievably congested side street to the detriment to those that live and work here.

Name:	Mr Nicholas Pestana		
Address and/or Residents Association:	Grosvenor Gardens Mews East London SW1W 0JW		
Received:	1 October 2015		
Status:	Resident	In support or opposed:	Opposed
<p>I am writing to object to this application on the grounds of 'prevention of public nuisance'.</p> <p>I live in Grosvenor Mews East which is at the back of the proposed restaurant site. I believe that the proposal is for all deliveries and waste collection will take place at the rear of the property via the mews. The mews is very small and any noise from these activities will cause a serious nuisance to all of the residents especially if they take place after the premises close at midnight or very early in the morning.</p> <p>In addition, it looks like this will be the staff entrance to the property which will again cause a disturbance as they leave in the early hours of the morning when their shifts end.</p>			
Name:	U Claxton		
Address and/or Residents Association:	7 Grosvenor Gardens Mews East London SW1W 0JN		
Received:	29 September 2015		
Status:	Resident	In support or opposed:	Opposed
<p>I am writing to register my representations regarding the above proposed New Premises Licence Application.</p>			

The application is for a restaurant with ancillary bar which will be open seven days a week from 07.00 to 23.30/00.00. The plans show a restaurant over two floors with 160+ covers.

The premises are located on an extremely busy road junction and it is therefore proposed that all “Goods In and Refuse out” will be via a Fire Escape door situated at the back of the property in Grosvenor Gardens Mews East.

This creates extremely significant safety, environmental and nuisance issues.

- a) The Mews is a very small and irregularly shaped area. It is already used by a number of business vehicles and also for the parking of Guests’ cars by the Goring Hotel. Its size, usage and physical irregularity make it totally unsuitable to accommodate lorries easily and safely.
- b) The Fire Exit door, which it is proposed to use for “Goods In and Refuse out”, is at the end of a long narrow section of alley.



The map included in the application shows that this narrow cobbled alley is 26.8m (88ft) in length and 6.09m (20ft) wide at its entry point. Half way down it narrows to 4.87m (16ft) and three quarters of the way down it narrows to only 3.04m (10ft).

Along the length, on both sides, of this narrow alley are doors leading directly into residential flats and offices,

Vehicles of any size, such as delivery lorries, would be physically unable to reach the end of the alley and would either have to stop part-way and then unload and transport goods along its length or would have to back in, both options noisy and potentially dangerous to residents and office staff.

- c) A restaurant/bar of the size proposed would require significant numbers of

deliveries seven days a week and the amount of refuse generated would also be considerable. The Mews is a residential area and these frequent and numerous movements would create unacceptable and unreasonable levels of noise and disruption.

- d) The Licence includes conditions regarding movement and storage of waste and recyclable materials between 23.00 and 08.00. However, there is no provision to ensure that waste is not placed outside during the day. Any food waste left in the Fire Exit area will inevitably attract vermin, something which is not a problem in the Mews at present.
- e) The proposed "Goods In and Refuse out" point is a Fire Escape, not just for the restaurant/bar but also for all the residents and office staff in the building above; this is its primary purpose and function and it should not be compromised for commercial purposes.

The location of 1 Grosvenor Gardens on a busy road junction makes it unsuitable for a development of this size and scope. It is totally unreasonable, environmentally unsound and simply unsafe and dangerous for the "Goods in and Refuse out" of such a huge restaurant/bar complex to be solely through a Fire Escape at the end of a long and narrow alley in a tiny residential Mews.

Name:		Ms Sian Davies	
Address and/or Residents Association:		Grosvenor Gardens Mews East London SW1W 0JW	
Received:	1 October 2015		
Status:	Resident	In support or opposed:	Opposed

I am writing to object to this application on the grounds of 'prevention of public nuisance'.

I live in Grosvenor Mews East which is at the back of the proposed restaurant site. I believe that the proposal is for all deliveries and waste collection will take place at the rear of the property via the mews. The mews is very small and any noise from these activities will cause a serious nuisance to all of the residents especially if they take place after the premises close at midnight or very early in the morning.

In addition, it looks like this will be the staff entrance to the property which will again cause a disturbance as they leave in the early hours of the morning when their shifts end.

3. Policy & Guidance

The following policies within the City Of Westminster Statement of Licensing Policy apply:	
Policy HRS1 applies:	(i) Applications for hours within the core hours set out below in this policy will generally be granted, subject to not being contrary to other policies in the Statement of Licensing Policy. (ii) Applications for hours outside the core hours set out below in this policy will be considered on their merits, subject to other relevant policies.
Policy PB1 applies:	Applications will only be granted if it can be demonstrated that the proposal meets the relevant criteria in Policies CD1, PS1, PN1 and CH1.
Policy RNT1 applies:	Applications will generally be granted and reviews determined, subject to the relevant criteria in Policies CD1, PS1, PN1 and CH1.

4. Appendices

Appendix 1	Premises plans
Appendix 2	Applicant supporting documents
Appendix 3	Premises history
Appendix 4	Proposed conditions
Appendix 5	Residential map and list of premises in the vicinity

Report author:	Mr Ola Owojori Senior Licensing Officer
Contact:	Telephone: 020 7641 7830 Email: owojori@westminster.gov.uk



- ▲ Fire alarm
- ▲ Fire extinguisher
- ▲ Fire escape
- ▲ Fire door
- ▲ Fire alarm pull station
- ▲ Fire alarm control panel
- ▲ Fire alarm bell
- ▲ Fire alarm horn
- ▲ Fire alarm siren
- ▲ Fire alarm speaker
- ▲ Fire alarm bell pull station
- ▲ Fire alarm control panel pull station
- ▲ Fire alarm bell pull station
- ▲ Fire alarm horn pull station
- ▲ Fire alarm siren pull station
- ▲ Fire alarm speaker pull station
- ▲ Fire alarm bell pull station
- ▲ Fire alarm control panel pull station
- ▲ Fire alarm bell pull station
- ▲ Fire alarm horn pull station
- ▲ Fire alarm siren pull station
- ▲ Fire alarm speaker pull station
- ▲ Fire alarm bell pull station
- ▲ Fire alarm control panel pull station
- ▲ Fire alarm bell pull station
- ▲ Fire alarm horn pull station
- ▲ Fire alarm siren pull station
- ▲ Fire alarm speaker pull station

Architect: [Faint text]
 Date: [Faint text]
 Scale: [Faint text]

Project Name	Lower Grosvenor Place
Client	Lower Grosvenor Place
Architect	[Faint text]
Date	[Faint text]
Scale	[Faint text]
Sheet No.	[Faint text]
Sheet Total	[Faint text]
Project No.	[Faint text]
Client No.	[Faint text]
Architect No.	[Faint text]
Date	[Faint text]
Scale	[Faint text]
Sheet No.	[Faint text]
Sheet Total	[Faint text]
Project No.	[Faint text]
Client No.	[Faint text]
Architect No.	[Faint text]
Date	[Faint text]
Scale	[Faint text]
Sheet No.	[Faint text]
Sheet Total	[Faint text]
Project No.	[Faint text]
Client No.	[Faint text]
Architect No.	[Faint text]
Date	[Faint text]
Scale	[Faint text]
Sheet No.	[Faint text]
Sheet Total	[Faint text]
Project No.	[Faint text]
Client No.	[Faint text]
Architect No.	[Faint text]
Date	[Faint text]
Scale	[Faint text]
Sheet No.	[Faint text]
Sheet Total	[Faint text]
Project No.	[Faint text]
Client No.	[Faint text]
Architect No.	[Faint text]
Date	[Faint text]
Scale	[Faint text]
Sheet No.	[Faint text]
Sheet Total	[Faint text]
Project No.	[Faint text]
Client No.	[Faint text]
Architect No.	[Faint text]
Date	[Faint text]
Scale	[Faint text]
Sheet No.	[Faint text]
Sheet Total	[Faint text]

Appendix 2

PSP

**PSP Consulting
16 Ledborough Lane
Beaconsfield
HP9 2PZ**

**1 GROSVENOR GARDENS, LONDON SW1W 0BG
(PER29)**

SERVICING MANAGEMENT PLAN

February 2016

**Prepared for
Grosvenor Gardens Leisure Ltd
Faiz Rasool
And
Buchanan Hartley Architects**

CONTENTS

	Page
1.0 Introduction	1
2.0 Background Information	1
3.0 Delivery and Servicing	2
4.0 Waste Management	4
5.0 Summary	7

DRAWINGS

Buchanan Hartley Drawing 0675 L(-)001 - Site Location Plan

Buchanan Hartley Drawing 0675 L(-)201 - Proposed Basement Plan

Buchanan Hartley Drawing 0675 L(-)202B - Proposed Ground Floor Plan

Drawing 706-001 - Preferred Delivery Location (On-Street)

Drawing 706-002 - Service Vehicle Swept Path (Transit or similar)

APPENDICES

Appendix 1 - Planning permission (13/11566/FULL)

Appendix 2 - Supplier Instructions Sheet

1. INTRODUCTION

1. Planning Permission has been granted for the use of the basement and ground floors at 1 Grosvenor Gardens, London, SW1W 0BG as a Restaurant (Class A3). This Servicing Management Plan has been prepared to address Planning Condition 11 of the planning permission 13/1156/FUL (**Appendix 1**), which states:

11. You must submit a detailed Servicing Management Plan for the approval of the City Council in consultation with Transport for London before occupation of the restaurant. The plan must include details of the management of waste, delivery vehicles, number of deliveries, time of deliveries and how deliveries will be managed. The restaurant use must then operate in accordance with the approved Servicing Management Plan.

Reason:

To make sure that the use will not cause nuisance for people in the area. This is as set out in S24, S29, and S32 of Westminster's City Plan: Strategic Policies adopted November 2013 and TACE 8 and ENV 6 of our Unitary Development Plan that we adopted in January 2007. (R05GB)

2. This Servicing Management Plan has been prepared by PSP Consulting (PSP) in accordance with advice from the City of Westminster and current TfL guidance contained in their document entitled: 'Delivery and Servicing Plans - Making Freight Work for You'.

3. As explained by TfL, delivery and servicing plans can provide a framework to make sure that freight vehicle activity is working effectively and to help to:

- Manage deliveries to reduce the number of trips, particularly during peak hours.
- Identify where safe and legal loading can take place.
- Use delivery companies who can demonstrate their commitment to best practice - for example, members of Freight Operator Recognition Scheme (FORS).

4. Delivery and servicing plans can also have advantages for suppliers and the local community, helping to:

- Save time and money.
- Reduce the environmental impact of the operation.
- Improve the safety of the delivery and servicing activity.
- Cut congestion in the local area.
- Ensure the operation is reliably supplied during planned events (such as the 2012 Games).

5. TfL suggest that delivery and servicing plans are updated each time the business or operations change, taking into account such matters as:

- Looking at where legal loading can take place.
- Using suppliers and freight operators who can demonstrate their commitment to best practice - for example, those accredited to FORS.
- Consolidating deliveries so fewer journeys are needed.
- Using more sustainable delivery methods.
- Working with other businesses or buildings in the area.
- Work with your suppliers to discuss the mutually beneficial options for receiving your goods or services.

2. BACKGROUND INFORMATION

6. The Planning Statement prepared by Buchanan Hartley Architects which accompanied planning application 13/11566/FULL explains that the existing building is a Grade II Listed Building, situated at the south east corner of the road junction between Grosvenor Gardens and Lower Grosvenor Place (see **Site Location Plan**). Pedestrian access is gained via a short flight of steps up to the Lobby and main entrance doors on Grosvenor Gardens. Other than via Grosvenor Gardens Mews East there is no vehicular access to the building. The upper four floor levels comprise residential accommodation, known as 1A Grosvenor Gardens, accessed via a flight of steps to a separate entrance on Lower Grosvenor Place. Both the above entrances and the door/fire exit to the rear yard and the Mews are shown on the **Proposed Ground Floor Plan**.

7. The Buchanan Hartley Design and Access Statement, also prepared to support the planning application, sets out at Section 7, the deliveries and waste disposal provision for the Restaurant, as follows:

- A goods reception and waste storage area is located at the rear of the premises at basement level, accessed directly off the main basement circulation route;
- A goods hoist is located within this area for the conveyance of goods and waste between basement floor level and ground level in the rear yard giving access to Grosvenor Gardens Mews East;
- Deliveries will be carried out via the Mews with incoming supplies / goods being transported manually from the delivery vehicle to the head of the service hoist; and
- The restaurant management will have a contract with an independent waste removal / recycling contractor for the daily removal of all kitchen and other waste, via the same procedure as above, in reverse.

8. The Buchanan Hartley **Proposed Ground Floor Plan** shows the main entrance to the restaurant from the corner of Grosvenor Gardens and Lower Grosvenor Place. This drawing also shows the staff entrance off Lower Grosvenor Place and the service / delivery access via the rear yard and the Mews.

3. DELIVERY AND SERVICING PROPOSALS

9. The aim of this Servicing Management Plan is to ensure that the right goods are delivered to the right place at the right time, as efficiently and as effectively as possible.

10. It is expected that there will be up to 5 deliveries per day to service the requirements of the fully operational Restaurant. These deliveries will take place between 0730hrs and 1600hrs on each weekday and between 0800hrs and 1300hrs on a Saturday. There will be no deliveries or collections on Sundays and Bank Holidays.

11. As shown on the **Site Location Plan** and as explained on the Supplier Instructions Sheet (**Appendix 2**), all deliveries will arrive and depart via Beeston Place. Vehicles can arrive at Beeston Place by two routes: southbound on Grosvenor Place and then turning left into Lower Grosvenor Place; or northbound on the A302 Grosvenor Gardens one-way system turning right into Lower Grosvenor Place. From Lower Grosvenor Place, Beeston Place is a right turn and is one-way southbound. Grosvenor Place, Lower Grosvenor Place and Grosvenor Gardens are TfL Red Routes where stopping, loading and unloading is not permitted.

12. A number of local establishments currently have their deliveries and servicing on-street from Beeston Place, particularly the Goring Hotel. The most likely point for loading and unloading associated with the Restaurant is on-street, just to the north of the Mews and on the west side of Beeston Place, as shown on **Drawing 706-001**. This is on the opposite side of the road and to the north of the usual delivery locations for the Goring Hotel and, given the small number of deliveries associated with the Restaurant, should not cause any conflict with the Goring Hotel servicing activities.

13. Larger delivery lorries will wait at the kerb side and incoming supplies will be transported manually from the delivery vehicle to the Restaurant rear yard adjacent to the service hoist, a distance of approximately 45 metres. Smaller delivery vehicles (Transit van or similar) will be able to reverse into the Mews and back up to the rear yard to unload (see **Drawing 706-002**).

14. Mews by their very nature are shared surfaces and residents and users will be aware of the likelihood of vehicular activity; reversing cannot be avoided in situations such as this type of Mews in London. As explained on the Supplier Instructions Sheet (**Appendix 2**) the Restaurant designated Banksman will guide drivers when reversing to enter or leave the Mews and when moving along the Mews.

15. The Restaurant Banksman will receive appropriate training, in accordance with the Health and the May 2013 Safety Executive leaflet INDG199(rev2). It is particularly important that a clear and recognised system for reversing is adopted; that the Restaurant Banksman is clearly visible to the delivery drivers at all times; and that the Banksman stands in a safe position throughout the reversing operation.

16. A copy of the Supplier Instructions Sheet, bearing the Restaurant Manager's contact details, will be provided to Mews residents and occupiers.

17. The Restaurant Manager will be responsible for confirming all orders of food, drink and consumables and for arranging laundry collections and deliveries. Orders will initially be placed on a daily basis and an on-line booking system will be established so that the suppliers can log their delivery time. This will make sure that deliveries do not arrive at conflicting times and thus that the time to undertake the delivery is optimised.

18. As the booking and delivery system settles down, suppliers will be asked to complete a supplier feedback form to consider how the delivery and servicing process can be made more efficient and more effective.

19. Planned events will be organised within the above delivery and servicing framework. Any abnormal activities will be discussed in advance with the Council, neighbouring residents and neighbouring businesses.

4. WASTE MANAGEMENT

20. The waste storage area is located at the rear of the premises at basement level, adjacent to the goods hoist (see **Proposed Basement Plan**) giving access to the rear yard and Grosvenor Gardens Mews East.

21. The restaurant will have a contract with an independent waste removal / recycling contractor for the daily removal of all kitchen and other waste, via the Mews. It is unlikely that refuse vehicles can reverse into the Mews and black bags and recycling containers will be transported manually to the refuse vehicle for loading on Beeston Place (see **Drawing 706-001**) .

22. It is expected that there will be 1 refuse and recycling collection per day to service the requirements of the fully operational Restaurant. These collections will take place between 0730hrs and 1600hrs on each weekday and between 0800hrs and 1300hrs on a Saturday. There will be no collections on Sundays and Bank Holidays.

23. As shown on the **Site Location Plan** and as explained on the Supplier Instructions Sheet (**Appendix 2**), all refuse/recycling vehicles will arrive and depart via Beeston Place. Vehicles can arrive at Beeston Place by two routes: southbound on Grosvenor Place or northbound on the A302 Grosvenor Gardens one-way system turning right into Lower Grosvenor Place. Waste/recycling contractors must bear in mind that Grosvenor Place, Lower Grosvenor Place and Grosvenor Gardens are TfL Red Routes where stopping is not permitted.

24. As discussed above, a number of local establishments are currently serviced on-street from Beeston Place, particularly the Goring Hotel. The one refuse/recycling collection per day for the Restaurant, should not cause any conflict with the Goring Hotel servicing activities.

25. Contractor's vehicles will wait at the kerb side (see **Drawing 706-001**) and waste and recycling bags/containers will be transported manually from the Restaurant rear yard, along Grosvenor Gardens Mews East, to the vehicle waiting in Beeston Place, a distance of approximately 45 metres.

26. The Restaurant Manager will be responsible for confirming refuse and recycling collection arrangements, in accordance with the Suppliers Instructions Sheet at **Appendix 2**. Collections will be confirmed via the Restaurant's on-line booking system which will enable all suppliers to log their arrival time. This will make sure that collections and deliveries do not arrive at conflicting times and thus that the time to undertake the collection or delivery is optimised.

27. A copy of the Supplier Instructions Sheet, bearing the Restaurant Manager's contact details, will be provided to Mews residents and occupiers.

28. Contractors will be asked to complete a supplier feedback form to consider how the delivery and servicing process can be made more efficient and more effective.

5. SUMMARY

29. This Servicing Management Plan has been prepared to address Planning Condition 11 of the planning permission for the use of the basement and ground floors at 1 Grosvenor Gardens, London, SW1W 0BG as a Restaurant. This Planning Condition requires the submission of a detailed Servicing Management Plan for the approval of the City Council in consultation with Transport for London before occupation of the restaurant. The plan must include details of the management of waste, delivery vehicles, number of deliveries, time of deliveries and how deliveries will be managed. The restaurant use must then operate in accordance with the approved Servicing Management Plan.

30. This Servicing Management Plan has been prepared in accordance with advice from the City of Westminster and current TfL guidance contained in their document entitled: 'Delivery and Servicing Plans - Making Freight Work for You'.

31. The Delivery and Servicing proposals and Waste Management strategy set out in this Servicing Management Plan (SMP) have been prepared as a non-technical everyday document for use by the future operators of the Restaurant. It considers what needs be delivered, in what form, when, by whom and clearly identify the delivery and collection process, storage locations, and the scheduling of deliveries linked to staffing arrangements.

32. The web-based delivery and collection arrangements, and Suppliers Instructions Sheet, explain how day to day deliveries and collections will occur and how the delivery vehicle size will be managed such that the time spent on the public highway will be minimised. The Servicing Management Plan will be kept under constant review and is intended to be effectively a good practice guide for the Restaurant operators.

PSP/February 2016.

DRAWINGS

Buchanan Hartley Drawing 0675 L(-)001 - Site Location Plan

Buchanan Hartley Drawing 0675 L(-)201 - Proposed Basement Plan

Buchanan Hartley Drawing 0675 L(-)202B - Proposed Ground Floor Plan

Drawing 706-001 - Preferred Delivery Location (On-Street)

Drawing 706-002 - Service Vehicle Swept Path (Transit or similar)

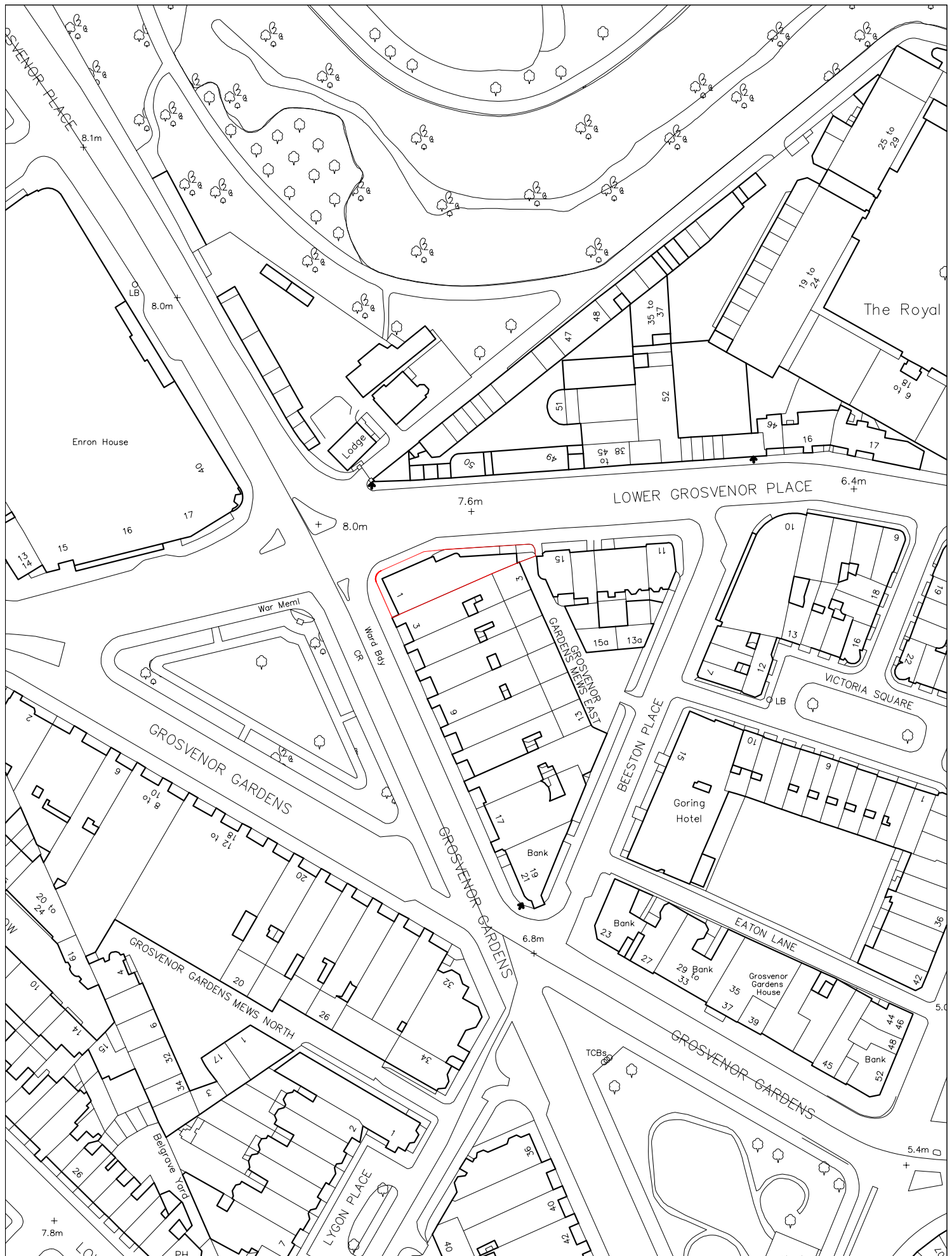

BUCHANAN ASSOCIATES
architects • interior designers

13 Grosvenor Gardens
London SW1W 0BD
t: 020 7392 7247
f: 020 7828 5663
email: mail@buchananarchitects.co.uk

TITLE
Mr F Rasool
1 Grosvenor Gardens SW1W 0BD
Site Location Plan

DATE	13.08.2012	SCALE	1:1250
DRAWN	GEJ	CHECKED	-
PROJECT NO	0675	DRAWING NO	L(-) 001
		REV	--

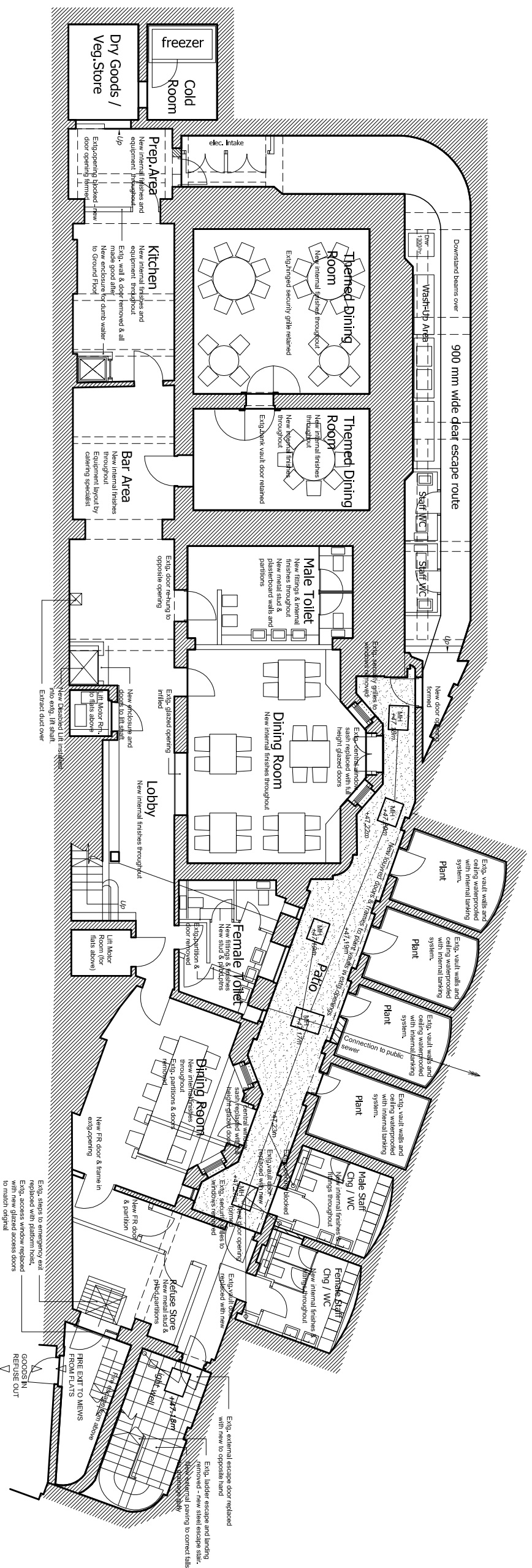
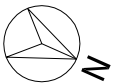

No.	Rev.	Description	Drawn By	Checked By

Planning

Client: Mr. Faiz Rasool

Project: 1 Grosvenor Gdns London SW1W 0BD
Proposed Restaurant

Scale: As Proposed

Date: 18.11.2013

Project No: L(-)-201

Buchanan Hatfield Architects Ltd
 ARCHITECTURE INTERIORS ENVIRONMENT

11 Grosvenor Gardens London SW1W 0BD
 T: 020 7592 7297
 F: 020 7592 7299
 E: info@bhanhfield.co.uk

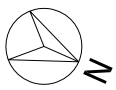

Grosvenor Gardens

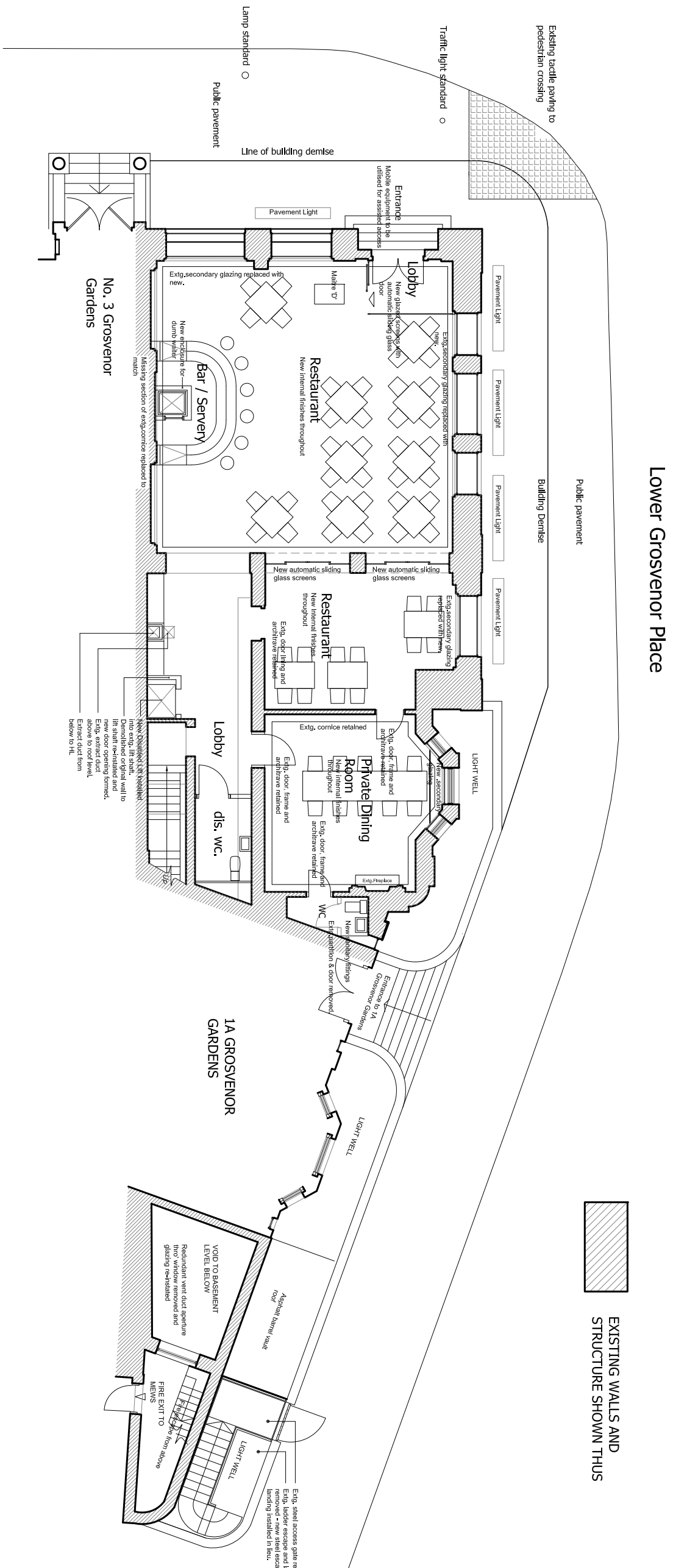

Lower Grosvenor Place

EXISTING WALLS AND STRUCTURE SHOWN THUS

<p>Buchanan Hatley Architects Ltd architects interior designers environmental 13 Grosvenor Gardens, London SW1W 0BD T: 020 7392 7297 E: info@bha.co.uk</p>	
Client	Mr. Faiz Rasool
Project	1 Grosvenor Gdns London SW1W 0BD Proposed Restaurant
Drawn	Ground Floor Plan As Proposed
Scale	1:100 @ A2
Date	18.11.2013
Drawn	CH
Checked	CH
Project No	0675
Drawn No	1(-)-202
Rev	B

© Buchanan Hatley Architects Ltd.
The information contained in this drawing is the copyright of Buchanan Hatley Architects Ltd, and must not be used in whole or in part without the express written approval of Buchanan Hatley Architects Ltd.
DO NOT SCALE FROM THIS DRAWING

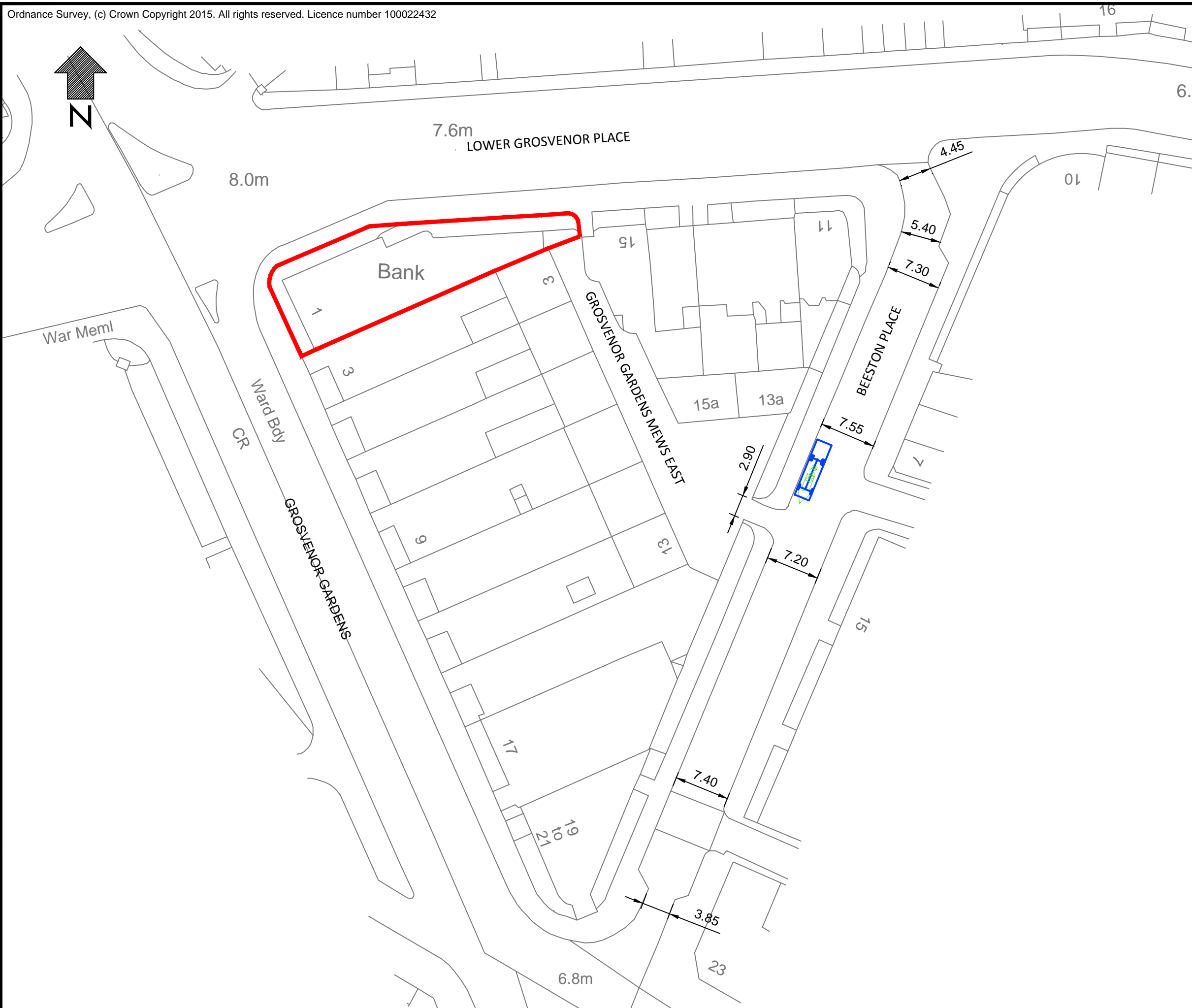

VEHICLE DETAILS:

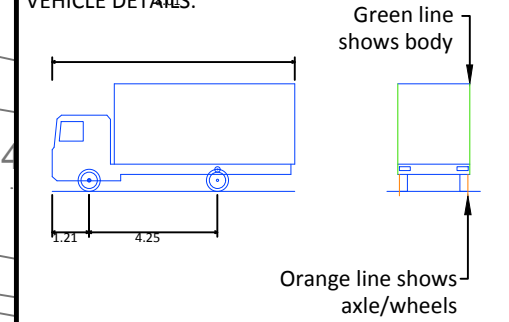

7.5T BOX VAN

Overall Length	8.010m
Overall Width	2.100m
Overall Body Height	3.556m
Min Body Ground Clearance	0.351m
Track Width	2.064m
Lock to Lock Time	4.00s
Kerb to Kerb Turning Radius	7.400m

Design speed 5kph for all Forward movements
Design speed 2.5kph for all Reverse movements

Rev	Date	Description	Drn	Chk	App
-	07/12/15	ORIGINAL ISSUE	AS	PG	PG

This drawing has been specifically prepared to meet the requirements of the named client and may contain design and innovative features which differ from conventional design standards.

www.cad-precision.com

CAD precision Ltd

Drawing produced on behalf of:

PSP consulting

M: +44 7887 701715
E: Patrick.Gurner@pspconsulting.co.uk

Client WORKING ON BEHALF OF

MR FAIZ RASOOL AND CALABRESE HOUSE

Project

1 GROSVENOR GARDENS LONDON

Drawing Title

KERBSIDE DELIVERIES
USING A 7.5T BOX VAN

Drawing Status

FOR INFORMATION

Drawn	Designed	Date	Scale	Size
AS	PG	DEC 2015	1:500	A3
Drawing No.	706-001			Rev
				-

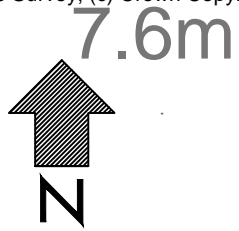

LOWER GROSVENOR PLACE

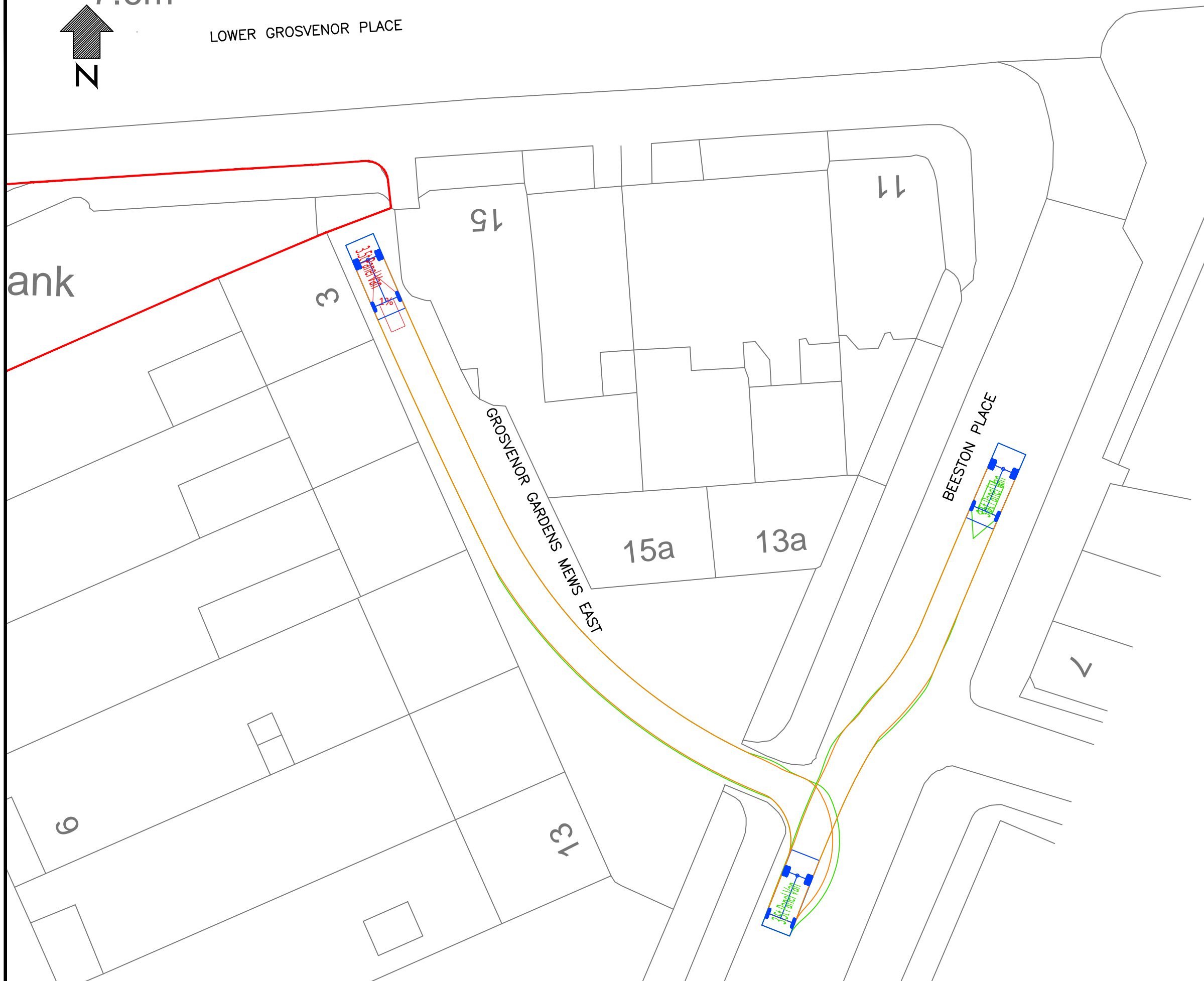

VEHICLE DETAILS:

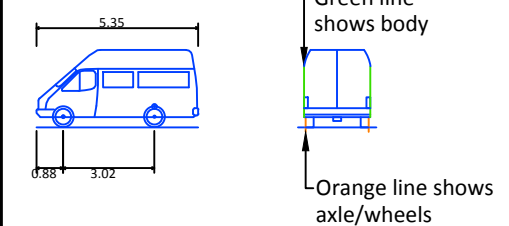

3.5T PANEL VAN

Overall Length	5.350m
Overall Width	1.970m
Overall Body Height	2.562m
Min Body Ground Clearance	0.335m
Max Track Width	1.970m
Lock to Lock Time	4.00s
Kerb to Kerb Turning Radius	5.850m

Design speed 5kph for all Forward movements
Design speed 2.5kph for all Reverse movements

Rev	Date	Description	Drn	Chk	App
-	07/12/15	ORIGINAL ISSUE	AS	PG	PG

This drawing has been specifically prepared to meet the requirements of the named client and may contain design and innovative features which differ from conventional design standards.

www.cad-precision.com

CAD precision Ltd

Drawing produced on behalf of:

PSP consulting

M: +44 7887 701715
E: Patrick.Gurner@pspconsulting.co.uk

Client WORKING ON BEHALF OF

MR FAIZ RASOOL AND CALABRESE HOUSE

Project

1 GROSVENOR GARDENS LONDON

Drawing Title

SWEPT PATH ANALYSIS USING A 3.5T PANEL VAN

Drawing Status

FOR INFORMATION

Drawn AS	Designed PG	Date DEC 2015	Scale 1:250	Size A3
Drawing No. 706-002				Rev -

APPENDIX 1

Appendix 1 - Planning permission (13/11566/FULL)



Your ref: MR FAIZ RASOOL
My ref: 13/11566/FULL

Please reply to: Vincent Nally
Tel No: 020 7641 5947
Email: southplanningteam@westminster.gov.uk

Derek Wickenden
Buchanan Associates Architects Ltd
13 Grosvenor Gardens
London
SW1W 0BD

Development Planning
Westminster City Hall
64 Victoria Street
London SW1E 6QP

1 May 2014

Dear Sir/Madam

**TOWN AND COUNTRY PLANNING ACT 1990
PERMISSION FOR DEVELOPMENT (CONDITIONAL)**

The City Council has considered your application and permits the development referred to below subject to the conditions set out and in accordance with the plans submitted.

Unless any other period is stated in the Schedule below or by conditions attached; this consent, by virtue of Section 91(1) of the Town and Country Planning Act 1990 (as amended), is granted subject to the condition that the development shall be commenced within 3 years of the date of this decision.

Your attention is drawn to the enclosed Statement of Applicant's Rights and General Information.

SCHEDULE

Application No:	13/11566/FULL	Application Date:	19.11.2013
Date Received:	20.11.2013	Date Amended:	16.12.2013
Plan Nos:	L(--)-001; L(--)-101; L(--)-102; L(--)-103; L(--)-104; L(--)-201; L(--)-202B; L(--)-203B; L(--)-204B; 17276a_01_P RevB; Environmental Noise Survey and NPPF Assessment; Ventilation and Extract Statement; Planning Statement; Impact Assessment; Design and Access Statement.		
Address:	1 Grosvenor Gardens, London, SW1W 0BG,		
Proposal:	Use of basement and ground floors as restaurant (Class A3). Installation of glazed doors and new escape stair within basement lighwell and plant within basement vaults.		

See next page for conditions/reasons.

Yours faithfully

Rosemarie MacQueen
Strategic Director Built Environment

Note - As the requirements of the Building Regulations may impact on the design of the proposed development, our Building Control team can offer advice and guidance at an early stage. If you would like to take advantage of this free service please contact **020 7641 7230** to arrange a preliminary discussion.

**Condition(s):**

- 1 The development hereby permitted shall be carried out in accordance with the drawings and other documents listed on this decision letter, and any drawings approved subsequently by the City Council as local planning authority pursuant to any conditions on this decision letter.

Reason:

For the avoidance of doubt and in the interests of proper planning.

- 2 You must carry out any building work which can be heard at the boundary of the site only:

- * between 08.00 and 18.00 Monday to Friday;
- * between 08.00 and 13.00 on Saturday; and
- * not at all on Sundays, bank holidays and public holidays.

Noisy work must not take place outside these hours. (C11AA)

Reason:

To protect the environment of neighbouring residents. This is as set out in S29 and S32 of Westminster's City Plan: Strategic Policies adopted November 2013 and ENV 6 of our Unitary Development Plan that we adopted in January 2007. (R11AC)

- 3 All new work to the outside of the building must match existing original work in terms of the choice of materials, method of construction and finished appearance. This applies unless differences are shown on the drawings we have approved or are required by conditions to this permission. (C26AA)

Reason:

To protect the special architectural or historic interest of this listed building and to make sure the development contributes to the character and appearance of the Grosvenor Gardens Conservation Area. This is as set out in S25 and S28 of Westminster's City Plan: Strategic Policies adopted November 2013 and DES 1, DES 10 (A) and paras 10.108 to 10.146 of our Unitary Development Plan that we adopted in January 2007. (R26FD)

- 4 (1) Where noise emitted from the proposed plant and machinery will not contain tones or will not be intermittent, the 'A' weighted sound pressure level from the plant and machinery (including non-emergency auxiliary plant and generators) hereby permitted, when operating at its noisiest, shall not at any time exceed a value of 10 dB below the minimum external background noise, at a point 1 metre outside any window of any residential and other noise sensitive property, unless and until a fixed maximum noise level is approved by the City Council. The background level should be expressed in terms of the lowest LA90, 15 mins during the proposed hours of operation. The plant-specific noise level should be expressed as LAeqTm, and shall be representative of the plant operating at its maximum.

(2) Where noise emitted from the proposed plant and machinery will contain tones or will be intermittent, the 'A' weighted sound pressure level from the plant and machinery (including non-emergency auxiliary plant and generators) hereby permitted, when operating at its

Note:

- The Plain English Crystal Mark applies to those conditions, reasons and informatives in this letter which have an associated reference number with the prefix C, R, X or I.
- The terms 'you' and 'your' include anyone who owns or occupies the land or is involved with the development.
- The terms 'us' and 'we' refer to the Council as local planning authority.





noisiest, shall not at any time exceed a value of 15 dB below the minimum external background noise, at a point 1 metre outside any window of any residential and other noise sensitive property, unless and until a fixed maximum noise level is approved by the City Council. The background level should be expressed in terms of the lowest LA90, 15 mins during the proposed hours of operation. The plant-specific noise level should be expressed as LAeqTm, and shall be representative of the plant operating at its maximum.

(3) Following installation of the plant and equipment, you may apply in writing to the City Council for a fixed maximum noise level to be approved. This is to be done by submitting a further noise report confirming previous details and subsequent measurement data of the installed plant, including a proposed fixed noise level for approval by the City Council. Your submission of a noise report must include:

- (a) A schedule of all plant and equipment that formed part of this application;
- (b) Locations of the plant and machinery and associated: ducting; attenuation and damping equipment;
- (c) Manufacturer specifications of sound emissions in octave or third octave detail;
- (d) The location of most affected noise sensitive receptor location and the most affected window of it;
- (e) Distances between plant & equipment and receptor location/s and any mitigating features that may attenuate the sound level received at the most affected receptor location;
- (f) Measurements of existing LA90, 15 mins levels recorded one metre outside and in front of the window referred to in (d) above (or a suitable representative position), at times when background noise is at its lowest during hours when the plant and equipment will operate. This acoustic survey to be conducted in conformity to BS 7445 in respect of measurement methodology and procedures;
- (g) The lowest existing L A90, 15 mins measurement recorded under (f) above;
- (h) Measurement evidence and any calculations demonstrating that plant and equipment complies with the planning condition;
- (i) The proposed maximum noise level to be emitted by the plant and equipment.

Reason:

Because existing external ambient noise levels exceed WHO Guideline Levels, and as set out in ENV 6 (1), (6) and (8) and ENV 7 (A)(1) of our Unitary Development Plan that we adopted in January 2007, so that the noise environment of people in noise sensitive properties is protected, including the intrusiveness of tonal and impulsive sounds; and as set out in S32 of Westminster's City Plan: Strategic Policies adopted November 2013, by contributing to reducing excessive ambient noise levels. Part (3) is included so that applicants may ask subsequently for a fixed maximum noise level to be approved in case ambient noise levels reduce at any time after implementation of the planning permission.

- 5 No vibration shall be transmitted to adjoining or other premises and structures through the building structure and fabric of this development as to cause a vibration dose value of greater than 0.4m/s (1.75) 16 hour day-time nor 0.26 m/s (1.75) 8 hour night-time as defined by BS 6472 (2008) in any part of a residential and other noise sensitive property.

Reason:

As set out in ENV6 (2) and (6) of our Unitary Development Plan that we adopted in January 2007, to ensure that the development is designed to prevent structural transmission of noise or vibration.

Note:

- The Plain English Crystal Mark applies to those conditions, reasons and informatives in this letter which have an associated reference number with the prefix C, R, X or I.
- The terms 'you' and 'your' include anyone who owns or occupies the land or is involved with the development.
- The terms 'us' and 'we' refer to the Council as local planning authority.





- 6 The design and structure of the development shall be of such a standard that it will protect residents within the same building or in adjoining buildings from noise and vibration from the development, so that they are not exposed to noise levels indoors of more than 35 dB LAeq 16 hrs daytime and of more than 30 dB LAeq 8 hrs in bedrooms at night.

Reason:

As set out in ENV6 (4) of our Unitary Development Plan that we adopted in January 2007, and the related Policy Application at sections 9.84 to 9.87, in order to ensure that design, structure and acoustic insulation of the development will provide sufficient protection for residents of the development from the intrusion of external noise.

- 7 Customers shall not be permitted within the restaurant premises before 0700 or after 2400 each day. (C12AD)

Reason:

To protect the environment of people in neighbouring properties as set out in S24, S29 and S32 of Westminster's City Plan: Strategic Policies adopted November 2013 and ENV 6, ENV 7 and TACE 8 of our Unitary Development Plan that we adopted in January 2007. (R12AC)

- 8 You must not allow more than 150 customers into the restaurant at any one time. (C05HA)

Reason:

We cannot grant planning permission for unrestricted use in this case because it would not meet TACE 8 of our Unitary Development Plan that we adopted in January 2007. (R05AB)

- 9 Before anyone moves into the property, you must provide the separate stores for waste and materials for recycling shown on drawing number L(--)-201. You must clearly mark them and make them permanently available and used for no other purpose.

Reason:

To protect the environment and provide suitable storage for waste as set out in S44 of Westminster's City Plan: Strategic Policies adopted November 2013 and ENV 12 of our Unitary Development Plan that we adopted in January 2007. (R14BD)

- 10 You must hang all doors or gates so that they do not open over or across the road or pavement. (C24AA)

Reason:

In the interests of public safety and to avoid blocking the road as set out in S41 of Westminster's City Plan: Strategic Policies adopted November 2013 and TRANS 2 and TRANS 3 of our Unitary Development Plan that we adopted in January 2007. (R24AC)

- 11 You must submit a detailed Servicing Management Plan for the approval of the City Council in consultation with Transport for London before occupation of the restaurant. The plan must include details of the management of waste, delivery vehicles, number of deliveries, time of deliveries and how deliveries will be managed. The restaurant use must then operate in accordance with the approved Servicing Management Plan.

Note:

- The Plain English Crystal Mark applies to those conditions, reasons and informatives in this letter which have an associated reference number with the prefix C, R, X or I.
- The terms 'you' and 'your' include anyone who owns or occupies the land or is involved with the development.
- The terms 'us' and 'we' refer to the Council as local planning authority.



Reason:

To make sure that the use will not cause nuisance for people in the area. This is as set out in S24, S29 and S32 of Westminster's City Plan: Strategic Policies adopted November 2013 and TACE 8 and ENV 6 of our Unitary Development Plan that we adopted in January 2007. (R05GB)

- 12 You must apply to us for approval of details of secure cycle storage for the restaurant use. You must not start any work on this part of the development until we have approved what you have sent us. You must then provide the cycle storage in line with the approved details prior to occupation and make it available at all times to everyone using the restaurant. You must not use the cycle storage for any other purpose.

Reason:

To provide cycle parking spaces for people using the development as set out in TRANS 10 of our Unitary Development Plan that we adopted in January 2007.

Informative(s):

- 1 In dealing with this application the City Council has implemented the requirement in the National Planning Policy Framework to work with the applicant in a positive and proactive way. We have made available detailed advice in the form of our statutory policies in Westminster's City Plan: Strategic Policies adopted November 2013, Unitary Development Plan, Supplementary Planning documents, planning briefs and other informal written guidance, as well as offering a full pre application advice service, in order to ensure that applicant has been given every opportunity to submit an application which is likely to be considered favourably. In addition, where appropriate, further guidance was offered to the applicant at the validation stage.
- 2 You may need to get separate permission under the Town and Country Planning (Control of Advertisements) (England) Regulations 2007 if you want to put up an advertisement at the property. (I03AA)
- 3 Please contact our Environmental Health Service (020 7641 2971) to register your food business and to make sure that all ventilation and other equipment will meet our standards. Under environmental health law we may ask you to carry out other work if your business causes noise, smells or other types of nuisance. (I06AA)
- 4 Please contact our Environmental Health Service (020 7641 2000) to make sure you meet their requirements under the Control of Pollution Act 1974 and the Environmental Protection Act 1990. (I07AA)
- 5 Please contact our Cleansing section on 020 7641 7962 about your arrangements for storing and collecting waste. (I08AA)
- 6 Please contact our District Surveyors' Services to discuss how you can design for the inclusion of disabled people. Email: districtsurveyors@westminster.gov.uk. Phone 020 7641 7240 or 020 7641 7230. If you make a further planning application or a building regulations application which relates solely to providing access or facilities for people with disabilities, our normal planning and building control fees do not apply.

Note:

- The Plain English Crystal Mark applies to those conditions, reasons and informatives in this letter which have an associated reference number with the prefix C, R, X or I.
- The terms 'you' and 'your' include anyone who owns or occupies the land or is involved with the development.
- The terms 'us' and 'we' refer to the Council as local planning authority.





The Equality and Human Rights Commission has a range of publications to assist you, see www.equalityhumanrights.com. The Centre for Accessible Environment's 'Designing for Accessibility', 2004, price £22.50 is a useful guide, visit www.cae.org.uk.

If you are building new homes you must provide features which make them suitable for people with disabilities. For advice see www.habinteg.org.uk

It is your responsibility under the law to provide good access to your buildings. An appropriate and complete Access Statement as one of the documents on hand-over, will provide you and the end user with the basis of a defence should an access issue be raised under the Disability Discrimination Acts.

- 7 You must make sure that any other activities taking place in the class A3 (restaurant or café) premises, such as small amounts of takeaway sales or small bar areas, are so minor that they do not alter the main use as a restaurant or café. If the scale of one or more of these extra activities is more substantial than this, it is likely that a material (significant) change of use (from class A3 to a mix of uses) will have taken place, which will need a new planning permission. (I61BA)
- 8 Conditions 4 and 5 control noise from the approved machinery. It is very important that you meet the conditions and we may take legal action if you do not. You should make sure that the machinery is properly maintained and serviced regularly. (I82AA)
- 9 You should contact Transport for London (TfL) due to Grosvenor Gardens and Lower Grosvenor Place being part of the TfL Road Network. TfL is the highway authority and may have their own requirements. Please contact Tom Wilson on 020 3054 7044.

Note:

- The Plain English Crystal Mark applies to those conditions, reasons and informatives in this letter which have an associated reference number with the prefix C, R, X or I.
- The terms 'you' and 'your' include anyone who owns or occupies the land or is involved with the development.
- The terms 'us' and 'we' refer to the Council as local planning authority.





City of Westminster

TOWN AND COUNTRY PLANNING ACT 1990 PLANNING (LISTED BUILDINGS AND CONSERVATION AREAS) ACT 1990

Applicant's Rights and General Information

1. Applicant's Rights (refusals and conditional approvals)

a) *Appeals to the Planning Inspectorate*

If your application has been **refused** by the City Council or **granted subject to conditions** that you are not happy with, you have the right to appeal to the Planning Inspectorate (under Section 78 of the Town and Country Planning Act 1990 or Section 20 of the Planning (Listed Buildings and Conservation Areas) Act 1990). The Planning Inspectorate is an Executive Agency reporting to the Secretary of State for Communities and Local Government.

The time limits for submitting an appeal may vary. The period after the date of the City Council's decision within which an appeal must be received by the Secretary of State is:

- **8 weeks** in the case of an appeal against refusal of advertisement consent.
- **12 weeks** in the case of appeals made under s78(1) against refusal of any 'householder application' – that is,
 - refusal of an application for planning permission to alter or extend a house, or for works within the curtilage of a house.
 - refusal to approve details submitted as required by a condition imposed on a permission granted for a householder application.
- **12 weeks** in the case of 'minor commercial applications that is,
 - refusal of an application for development of an existing building or part of a building currently in use for any purposes in Classes A1, A2, A3, A4 and A5 where the proposal does not include a change of use, a change to the number of units, development that is not wholly at ground floor level and/or does not increase the gross internal area of the building.
- **6 months** in the case of all other appeals made under s78(1) or s20 of the above Acts relating to a decision on a planning application or listed building/conservation area consent application. The 6 month time limit also applies to any appeal made under s78(2) of the Act in respect of a failure to give a decision within the statutory period.

If you want to appeal, you must use the correct appeal form from the following list: Planning, Householder, Minor Commercial, Listed Building Consent or Certificate of Lawful Use or Development.

The Planning Inspectorate has an online appeals service: www.planningportal.gov.uk/pcs. The Inspectorate will publish details of your appeal on the internet (on the Appeals area of the Planning Portal). This may include a copy of the application form and associated documents and the completed appeal documents. Please ensure that you only provide information, including personal information, that you are happy will be made available to others in this way. If you supply personal information belonging to a third party please ensure that you have their permission to do so. More detailed information about data protection and privacy matters is available on the Planning Portal. Alternatively, you can obtain a form from the **Planning Inspectorate, 3/08a, Kite Wing, Temple Quay House, 2 The Square, Temple Quay, Bristol BS1 6PN Tel: 0117 372 8000 Fax: 0117 372 8443**. An extension of time for lodging an appeal is unlikely to be granted except in special circumstances. There is a guide and other useful advice about appeals on line at www.planningportal.gov.uk/pcs.

APPENDIX 2

Appendix 2 - Supplier Instructions Sheet

RESTAURANT AT 1 GROSVENOR GARDENS LONDON

SUPPLIER INSTRUCTIONS SHEET SERVICING MANAGEMENT PLAN APPENDIX 2

1. The Restaurant Manager will be responsible for placing and confirming all orders for food, drink and consumables and for arranging laundry collections and deliveries. The Restaurant Manager will also arrange all waste and recycling collections.

- Restaurant Manager mobile telephone no. - 07xxxxxxxxx
- Restaurant Manager land line telephone no. - 020 xxxx xxxx

2. Orders will be placed on a daily basis and, once their orders are confirmed, suppliers must log their delivery/collection time via the Restaurant on-line booking system (see below), for every delivery. This will make sure that deliveries do not arrive at conflicting times and thus that the time to undertake the delivery is optimised.

- Restaurant on-line booking system - www.1GrosvenorGardens.co.uk

3. All deliveries and collections will arrive at Point B on the plan below (post code **SW1W xxx**) and load/unload at the kerbside as shown on **Drawing 760-001** (attached)

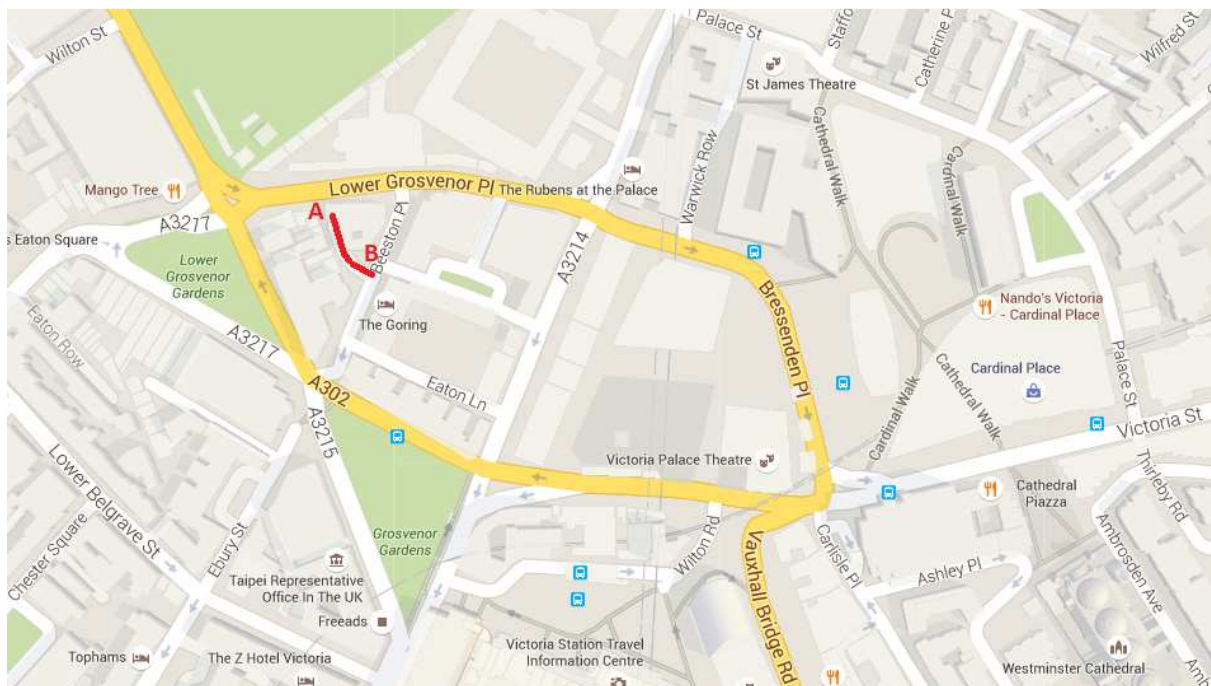

4. All deliveries will arrive and depart via Beeston Place. Vehicles can arrive at Beeston Place by two routes: southbound on Grosvenor Place and then turning left into Lower Grosvenor Place; or northbound on the A302 Grosvenor Gardens one-way system turning right into Lower Grosvenor Place. From Lower Grosvenor Place, Beeston Place is a right turn and is one-way southbound. Grosvenor Place, Lower Grosvenor Place and Grosvenor Gardens are TfL Red Routes where stopping, loading and unloading is not permitted.

5. Deliveries and collections will take place between 0700hrs and 1600hrs on each weekday and between 0800hrs and 1300hrs on a Saturday. There will be no deliveries or collections on Sundays and Bank Holidays.

6. Larger delivery lorries will wait at the kerb side and incoming supplies will be transported manually from the delivery vehicle to the Restaurant rear yard adjacent to the service hoist, a distance of approximately 45m (Point B to Point A on the above plan). Smaller delivery vehicles (Transit or similar) will be able to reverse into the Mews and back up to the rear yard at Point A to unload (see also attached **Drawing 706-002**).

7. Before leaving Point B, suppliers must ensure that they are accompanied and supervised by the Restaurant Banksman who will guide drivers when reversing to enter or leave the Mews and when moving along the Mews. The Restaurant Manager (on the above phone numbers) will despatch the Banksman when requested by the delivery driver. The Restaurant Banksman will make sure that he is clearly visible to the delivery drivers at all times and he will stand in a safe position throughout the reversing operation.

8. On a monthly basis, suppliers will be asked to complete a feedback form, via the above Restaurant website, to consider:

- is the on-line booking system operating successfully;
- rescheduling deliveries outside of peak hours;
- whether it would be practical to have larger deliveries, less often;
- can we consolidate/reduce suppliers, waste and recycling collections;
- are there improvements that could be considered;
- should targets be introduced;
- is it possible for cooperative working with tenants and neighbours;
- can the supplier use low or no emission vehicles;

- is the location map appropriate and are the contacts accessible;
- do you operate under the FORS Freight Operator Recognition System;

PSP/December 2015

There is no licence or appeal history for the premises

CONDITIONS CONSISTENT WITH THE OPERATING SCHEDULE AND CONDITIONS PROPOSED BY A PARTY TO THE HEARING

When determining an application for a new premises licence under the provisions of the Licensing Act 2003, the licensing authority must, unless it decides to reject the application, grant the licence subject to the conditions which are indicated as mandatory in this schedule.

At a hearing the licensing authority may, in addition, and having regard to any representations received, grant the licence subject to such conditions which are consistent with the operating schedule submitted by the applicant as part of their application, or alter or omit these conditions, or add any new condition to such extent as the licensing authority considers necessary for the promotion of the licensing objectives.

This schedule lists those conditions which are consistent with the operating schedule, or proposed as necessary for the promotion of the licensing objectives by a responsible authority or an interested party as indicated. These conditions have not been submitted by the licensing service but reflect the positions of the applicant, responsible authority or interested party and have not necessarily been agreed

Mandatory Conditions

1. No supply of alcohol may be made at a time when there is no designated premises supervisor in respect of this licence.
2. No supply of alcohol may be made at a time when the designated premises supervisor does not hold a personal licence or the personal licence is suspended.
3. Every supply of alcohol under this licence must be made or authorised by a person who holds a personal licence.
4.
 - (1) The responsible person must ensure that staff on relevant premises do not carry out, arrange or participate in any irresponsible promotions in relation to the premises.
 - (2) In this paragraph, an irresponsible promotion means any one or more of the following activities, or substantially similar activities, carried on for the purpose of encouraging the sale or supply of alcohol for consumption on the premises—
 - (a) games or other activities which require or encourage, or are designed to require or encourage, individuals to;
 - (i) drink a quantity of alcohol within a time limit (other than to drink alcohol sold or supplied on the premises before the cessation of the period in which the responsible person is authorised to sell or supply alcohol), or
 - (ii) drink as much alcohol as possible (whether within a time limit or otherwise);
 - (b) provision of unlimited or unspecified quantities of alcohol free or for a fixed or discounted fee to the public or to a group defined by a particular characteristic in a manner which carries a significant risk of undermining a licensing objective;
 - (c) provision of free or discounted alcohol or any other thing as a prize to encourage or reward the purchase and consumption of alcohol over a period of 24 hours or

less in a manner which carries a significant risk of undermining a licensing objective;

- (d) selling or supplying alcohol in association with promotional posters or flyers on, or in the vicinity of, the premises which can reasonably be considered to condone, encourage or glamorise anti-social behaviour or to refer to the effects of drunkenness in any favourable manner;
 - (e) dispensing alcohol directly by one person into the mouth of another (other than where that other person is unable to drink without assistance by reason of a disability).
5. The responsible person must ensure that free potable water is provided on request to customers where it is reasonably available.
6. (1) The premises licence holder or club premises certificate holder must ensure that an age verification policy is adopted in respect of the premises in relation to the sale or supply of alcohol.
- (2) The designated premises supervisor in relation to the premises licence must ensure that the supply of alcohol at the premises is carried on in accordance with the age verification policy.
- (3) The policy must require individuals who appear to the responsible person to be under 18 years of age (or such older age as may be specified in the policy) to produce on request, before being served alcohol, identification bearing their photograph, date of birth and either—
- (a) a holographic mark, or
 - (b) an ultraviolet feature.
7. The responsible person must ensure that—
- (a) where any of the following alcoholic drinks is sold or supplied for consumption on the premises (other than alcoholic drinks sold or supplied having been made up in advance ready for sale or supply in a securely closed container) it is available to customers in the following measures—
 - (i) beer or cider: ½ pint;
 - (ii) gin, rum, vodka or whisky: 25 ml or 35 ml; and
 - (iii) still wine in a glass: 125 ml;
 - (b) these measures are displayed in a menu, price list or other printed material which is available to customers on the premises; and
 - (c) where a customer does not in relation to a sale of alcohol specify the quantity of alcohol to be sold, the customer is made aware that these measures are available.

A responsible person in relation to a licensed premises means the holder of the premise licence in respect of the premises, the designated premises supervisor (if any) or any individual aged 18 or over who is authorised by either the licence holder or designated premises supervisor. For premises with a club premises certificate, any member or officer of the club present on the premises in a capacity that which enables him to prevent the supply of alcohol.

8(i) A relevant person shall ensure that no alcohol is sold or supplied for consumption on or off the premises for a price which is less than the permitted price.

8(ii) For the purposes of the condition set out in paragraph 8(i) above -

(a) "duty" is to be construed in accordance with the Alcoholic Liquor Duties Act 1979;

(b) "permitted price" is the price found by applying the formula -

$$P = D + (D \times V)$$

Where -

(i) P is the permitted price,

(ii) D is the amount of duty chargeable in relation to the alcohol as if the duty were charged on the date of the sale or supply of the alcohol, and

(iii) V is the rate of value added tax chargeable in relation to the alcohol as if the value added tax were charged on the date of the sale or supply of the alcohol;

(c) "relevant person" means, in relation to premises in respect of which there is in force a premises licence -

(i) the holder of the premises licence,

(ii) the designated premises supervisor (if any) in respect of such a licence, or

(iii) the personal licence holder who makes or authorises a supply of alcohol under such a licence;

(d) "relevant person" means, in relation to premises in respect of which there is in force a club premises certificate, any member or officer of the club present on the premises in a capacity which enables the member or officer to prevent the supply in question; and

(e) "value added tax" means value added tax charged in accordance with the Value Added Tax Act 1994.

8(iii). Where the permitted price given by Paragraph 8(ii)(b) above would (apart from this paragraph) not be a whole number of pennies, the price given by that sub-paragraph shall be taken to be the price actually given by that sub-paragraph rounded up to the nearest penny.

8(iv). (1) Sub-paragraph 8(iv)(2) below applies where the permitted price given by Paragraph 8(ii)(b) above on a day ("the first day") would be different from the permitted price on the next day ("the second day") as a result of a change to the rate of duty or value added tax.

(2) The permitted price which would apply on the first day applies to sales or supplies of alcohol which take place before the expiry of the period of 14 days beginning on the second day.

Conditions consistent with the operating schedule

9. Save for the area hatched black on the plan, the supply of alcohol at the premises shall only be to a person seated taking a table meal there and for consumption by such a person as ancillary to their meal.
10. Substantial food and non-intoxicating beverages, including drinking water shall be available in all parts of the premises where alcohol is sold or supplied for consumption on the premises.
11. The venue will install and maintain a comprehensive CCTV system as per the minimum requirements of a Metropolitan Police Crime Prevention Officer. All entry points will be covered enabling frontal identification of every person entering in any light condition. The CCTV system shall continually record whilst the venue is open for licensable activities for a period of 31 days with date and time stamping. Recordings shall be made available, immediately upon the request of Police or authorised officer throughout the preceding 31 days.
12. A staff member from the Premises who is conversant with the operation of the CCTV system shall be on the Premises at all times when the Premises is open to the public. This staff member shall be able to show Police recent data or footage with the absolute minimum of delay when requested.
13. Challenge 21, a proof of age scheme shall be operated at the premises where the only acceptable forms of identification are recognised photographic identification cards, such as a driving licence or passport.
14. An incident log shall be kept at the premises, and made available on request to an authorised officer of the City Council or the Police, which will record the following:
 - i) all crimes reported to the venue
 - ii) all ejections of patrons
 - iii) any complaints received
 - iv) any incidents of disorder
 - v) all seizures of drugs or offensive weapons
 - vi) any faults in the CCTV system
 - vii) any refusal of the sale of alcohol
 - viii) any visit by a relevant authority or emergency service.
15. No noise shall emanate from the premises nor vibration be transmitted through the structure of the premises which gives rise to a nuisance. **Alternative at condition 28**
16. Notices shall be prominently displayed at all exits requesting patrons to respect the needs of local residents and businesses and leave the area quietly.
17. All waste shall be properly presented and placed out for collection no earlier than 30 minutes before the scheduled collection times.
18. No waste or recyclable materials, including bottles, shall be moved, removed from or placed in outside areas between 23:00 and 08:00 hours on the following day. **Alternative to condition 29**

19. During the hours of operation of the premises, the licence holder shall ensure sufficient measures are in place to remove and prevent litter or waste arising or accumulating from customers in the area immediately outside the premises and that this area shall be swept and or washed and litter and sweeping collected and stored in accordance with the approved refuse storage arrangements by close of business.
20. There shall be no striptease or nudity, and all persons shall be decently attired at all times, except when the premises are operating under the authority of a sexual entertainment Venue Licence.
21. Patrons permitted to temporarily leave and then re-enter the premises, e.g. to smoke shall not be permitted to take drinks or glass containers with them.
22. The number of persons accommodated at the premises (excluding staff) shall not exceed []. **Alternative at condition 27**
23. The licence will have no effect until the Licensing authority are satisfied that the premises is constructed or altered in accordance with the appropriate provisions of the district Surveyor's Association – technical Standards for Paces of Entertainment and the reasonable requirements of Westminster environmental Health Consultation team, at which time this condition will be removed from the licence.

Conditions agreed with the Police

24. All sales of alcohol for consumption off the premises shall be in sealed containers only and shall not be consumed on the premises.
25. The supply of alcohol for consumption 'On' the premises shall be by waiter/waitress or bar service only.
26. There shall be no supply of alcohol for consumption 'Off' the premises after 22.00 hours.

Conditions proposed by the Environmental Health

27. The number of persons permitted in the premises at any one time (excluding staff) shall not exceed
 - i. Ground Floor xxx persons.
 - ii. Basement xxx persons.
28. No noise generated on the premises, or by its associated plant or equipment, shall emanate from the premises nor vibration be transmitted through the structure of the premises which gives rise to a nuisance.
29. No collections of waste or recycling materials (including bottles) from the premises shall take place between 23.00 and 08.00 hours on the following day.
30. No deliveries to the premises shall take place between 21.00 and 08.00 hours on the following day.

31. The emergency exit door leading onto Grosvenor Gardens Mews East shall be self-closing and remain closed when the premises are operating under the authority of the licence.
32. The approved arrangements at the premises, including means of escape provisions, emergency warning equipment, the electrical installation and mechanical equipment, shall at all material times be maintained in good condition and full working order.
33. The means of escape provided for the premises shall be maintained unobstructed, free of trip hazards, be immediately available and clearly identified in accordance with the plans provided.
34. All emergency exit doors shall be available at all material times without the use of a key, code, card or similar means.
35. All emergency doors shall be maintained effectively self-closing and not held open other than by an approved device.
36. The edges of the treads of steps and stairways shall be maintained so as to be conspicuous.
37. Curtains and hangings shall be arranged so as not to obstruct emergency safety signs or emergency equipment.

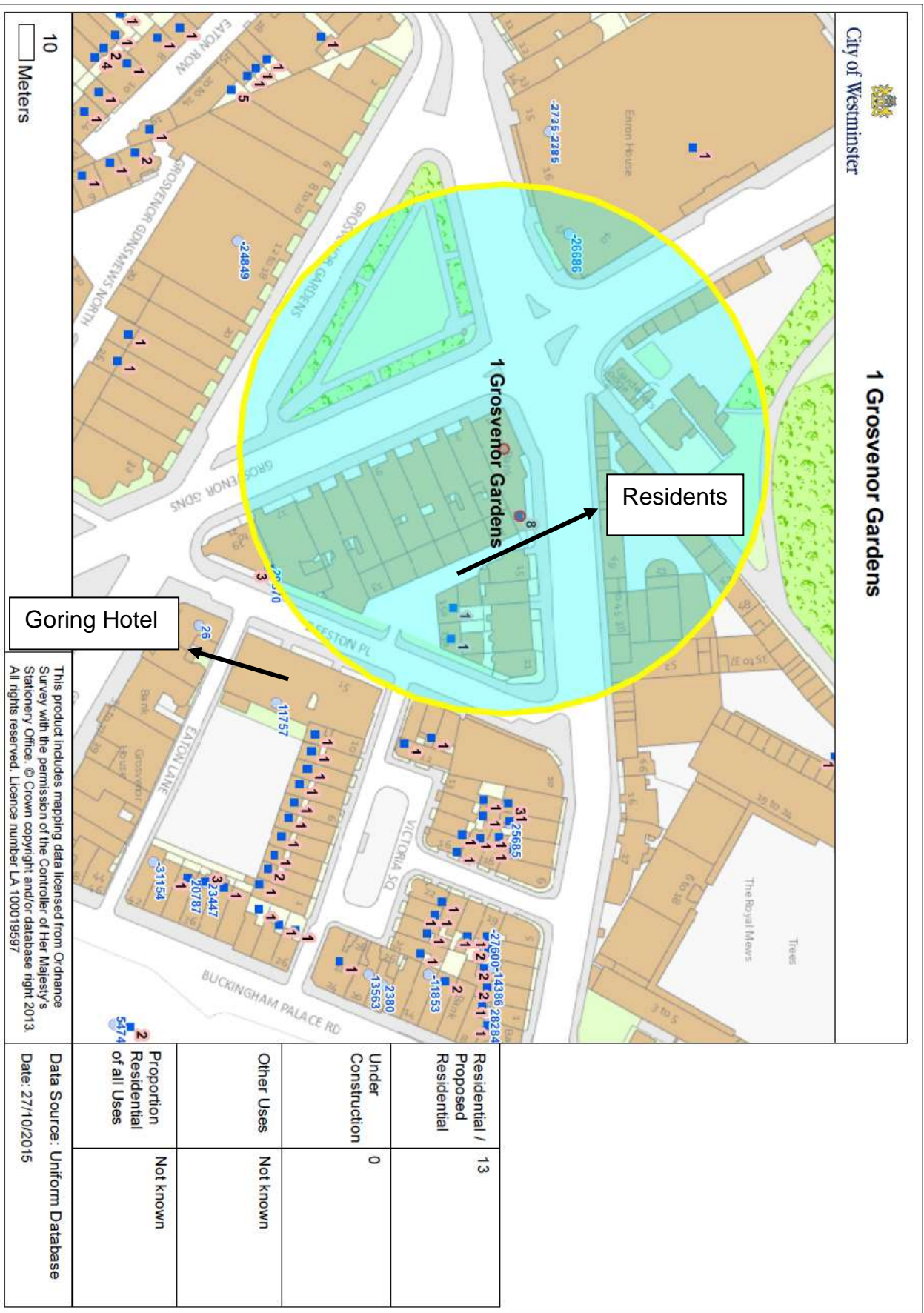

If you have any queries about this report or wish to inspect one of the background papers please contact the report author.

Background Documents – Local Government (Access to Information) Act 1972

1	Licensing Act 2003	N/A
2	City of Westminster Statement of Licensing Policy	7 th January 2011
3	Amended Guidance issued under section 182 of the Licensing Act 2003	March 2015
4	Acknowledgement and service	7 September 2015
5	Application form	7 September 2015
6	Application notice	7 September 2015
7	Copy of blue notice	7 September 2015
8	Mailing list	7 September 2015
9	Resident notification to print room	7 September 2015
10	Plan	7 September 2015
11	Goring Hotel representation	29 September 2015
12	U Claxton representation	30 September 2015
13	Nicholas Pestana representation	1 October 2015
14	Sean Stowell representation	1 October 2015
15	Imogen Badley representation	1 October 2015
16	Sian Davies representation	1 October 2015
17	U Claxton supporting representation	2 October 2015
18	Environmental Health representation	2 October 2015
19	Police representation, conditions and withdrawal	7 October 2015
20	Notification of hearing to applicant	27 October 2015
21	Notification of hearing to objectors	27 October 2015
22	Proposed Environmental Health conditions	4 November 2015
23	Revised hearing notification	16 February 2016
24	Applicant submission	16 February 2016